

ECONOMY WIRE REEL CADDY - WIRE-D-E

APPROX WEIGHT: 45 lbs.
 DOES NOT INCLUDE WEIGHT OF POWER OR PACKAGING!!!

*** ANY ADDITIONS, DELETIONS, OR OMISSIONS MUST BE CORRECTED ON THIS DRAWING AS THIS DRAWING WILL BE CONSIDERED ALL INCLUSIVE ***

ALL GRAPHICS PROVIDED ARE FOR REFERENCE ONLY. IF CERTAIN DIMENSIONS ARE CRITICAL PLEASE VERIFY THOSE DIMENSIONS WITH YOUR SALESPERSON

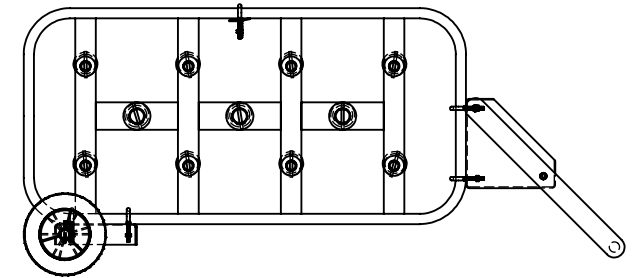
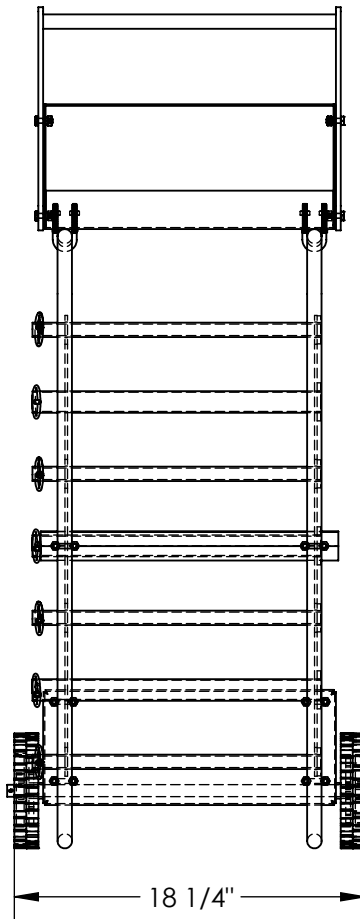
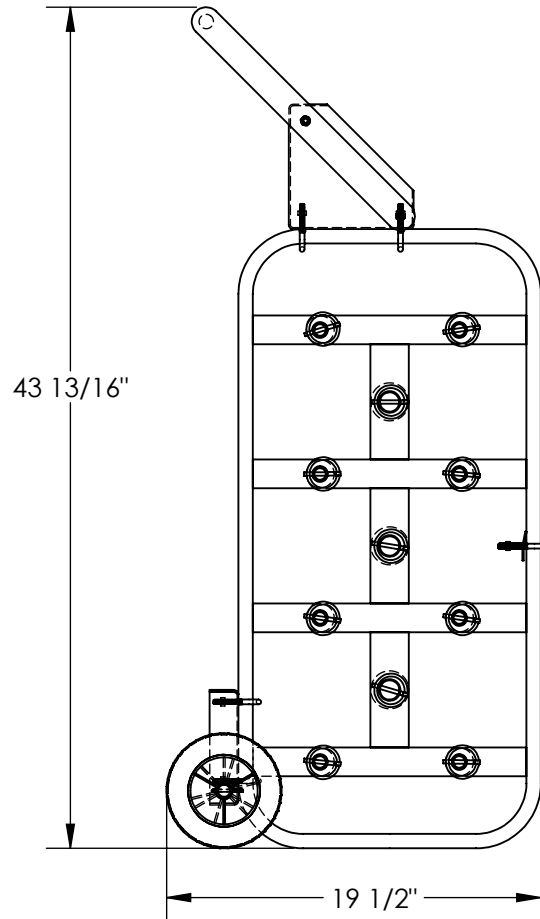

HORIZONTAL VIEW
 SCALE: 1:14

DIMENSION TOLERANCE $\pm 1/4"$

STANDARD FEATURES

- MODEL NUMBER IS WIRE-D-E
- OVERALL WIDTH IS 18 1/4"
- OVERALL DEPTH IS 19 1/2"
- OVERALL HEIGHT IS 43 13/16"
- (LARGE SPOOL AXLE) MAX REEL DIAMETER: 14"
- (SMALL SPOOL AXLE) MAX REEL DIAMETER: 7"
- MAX CAPACITY IS 150 LBS UNIFORMLY DISTRIBUTED
- TOOL TRAY SIZE: 15 1/4" X 6 1/2" X 6 1/2"
- 6" X 1 1/4" SEMI PNEUMATIC WHEELS
- DURABLE LIQUID PAINT BLUE FINISH

SPECIAL FEATURES

NONE

APPROVAL

I, THE UNDERSIGNED, AGREE THAT THE PRODUCT AS REPRESENTED SATISFIES DESIGN AND DIMENSION REQUIREMENTS. I ALSO ACKNOWLEDGE MY DUTY TO CONFIRM PRODUCT AND INSTALLATION COMPLIANCE WITH ALL APPLICABLE FEDERAL, STATE AND LOCAL REGULATIONS AND STANDARDS.

UNITS REQUIRING APPROVAL DRAWINGS OR MODIFIED ARE NON-RETURNABLE

[] As drawn [] As marked

Signed: _____ Date: _____

Printed Name: _____

LEAD TIME WILL START UPON RECEIPT OF SIGNED APPROVAL DRAWING

DISTRIBUTOR'S NAME:		P.O.#
VESTIL MANUFACTURING		X
DRAWN BY: NBE	DATE: 09/21/2022	W.O.#
REFERENCE: X	SCALE: 1:10	X
QUOTED LEAD TIME: X	QUOTE #	SALES: X
	X	FILE NAME:
		31-007-099